

# Instruction Manual for 1-Phase 1Q-Power Controller Temvar GEE2

## TABLE OF CONTENTS

|           |   |           |
|-----------|---|-----------|
| <b>1</b>  | <b>SAFETY AND APPLICATION NOTES FOR DRIVE CONVERTERS</b>      | <b>2</b>  |
| <b>2</b>  | <b>DEVICE DESCRIPTION</b>                                     | <b>3</b>  |
| 2.1       | General   | 3         |
| 2.2       | Device Construction   | 3         |
| 2.3       | Ambient Conditions  | 4         |
| 2.4       | System Power Relationships                                    | 4         |
| <b>3</b>  | <b>PRODUCT OVERVIEW</b>                                       | <b>5</b>  |
| 3.1       | Device Table  | 5         |
| 3.2       | Dimensions of Chokes and Devices                              | 6         |
| <b>4</b>  | <b>DEVICE CONNECTION</b>                                      | <b>7</b>  |
| 4.1       | Terminal Diagram  | 7         |
| 4.2       | Switch ON/OFF Sequence  | 7         |
| 4.3       | Terminal Allocation   | 8         |
| 4.4       | Assembly  | 9         |
| 4.4.1     | Danger  | 9         |
| 4.4.2     | Mechanical Construction                                       | 10        |
| 4.4.3     | Wiring Notes  | 10        |
| <b>5</b>  | <b>OVERVIEW DIAGRAMS</b>                                      | <b>11</b> |
| 5.1       | Circuit Diagram   | 11        |
| 5.2       | Device Mounting   | 12        |
| 5.3       | Component Mounting Diagram for the Electronics Circuit Boards | 13        |
| 5.4       | Potentiometer Settings  | 14        |
| 5.5       | LED Indicators  | 15        |
| <b>6</b>  | <b>DESCRIPTION OF THE INPUT AND OUTPUT FUNCTIONS</b>          | <b>16</b> |
| 6.1       | Analog Inputs   | 16        |
| 6.2       | Analog Outputs  | 17        |
| 6.3       | Control Inputs and Indicator Outputs                          | 18        |
| <b>7</b>  | <b>DESCRIPTION OF FUNCTIONS</b>                               | <b>20</b> |
| 7.1       | Setpoint Value Integrator                                     | 20        |
| 7.2       | Speed Closed-Loop Controller                                  | 21        |
| 7.3       | Current Limits  | 21        |
| 7.4       | Closed-Loop Current Controller                                | 22        |
| 7.5       | Firing Pulse Formation  | 22        |
| 7.6       | Thyristor/Diode Output Stage                                  | 23        |
| 7.7       | Electronics Supply  | 23        |
| 7.8       | Field Supply  | 23        |
| <b>8</b>  | <b>START-UP</b>   | <b>24</b> |
| 8.1       | Danger  | 24        |
| 8.2       | Recommended Actions   | 25        |
| <b>9</b>  | <b>OPTIMIZING</b>   | <b>26</b> |
| <b>10</b> | <b>Malfunctions</b>   | <b>27</b> |

Updated edition: A0256\_06 - date of last revision: July 8, 2009/ KB



1

## D 96.091101E SAFETY AND APPLICATION NOTES FOR DRIVE CONVERTERS

(according to the 72/73/EC Low-voltage Guideline)

10.25.96/HX/PT/BLY

### 1. General

Depending on their protection class, drive converters may have non-isolated and live conductors, possibly moving or rotating parts, and hot surfaces.

There is danger of severe personnel or equipment damage if the required cover is inadmissibly removed, the unit is used in an inadmissible application, improperly installed or operated.

Refer to the documentation for further information.

All work concerning transportation, installation, and commissioning as well as maintenance is to be performed by **qualified expert personnel** (take also note of the IEC 364 and/or DIN VDE 0100 and national accident prevention regulations).

#### Expert personnel for electrical devices

Personnel, which is based on his/her professional training, experience and knowledge of the applicable standards and capable to judge the tasks to be performed and to recognize possible sources of danger.

#### Personnel trained for electro-technical operation

Personnel informed by the expert personnel for electrical devices regarding the tasks assigned to him/her and the possible danger occurring at improper actings and who is trained if required and instructed about the required safety mechanisms and protective measures.

### 2. Intended use

Drive converters are components supposed to be included into electrical equipment or machines.

When installing the drive converter into a machine, its commissioning (i. e. taking up its intended operation) is prohibited until it is ascertained that the machine conforms to the regulations described by the EC guideline 93/44/EC (Machine Guideline). Take note of EN 60204.

Commissioning (i. e. taking up its intended operation) is only allowed if the Electromagnetic Compatibility guideline (89/336/EC) is observed.

The drive converters fulfill the requirements of the 73/23/EC Low-voltage Guideline. Drive converters are subject to the harmonized standards of the prEN 50178/DIN VDE 0160 in association with EN 60439-1/VDE 0660 part 500 and EN 60146/VDE 0558.

The specifications and the data concerning the connection conditions are stated on the rating plate and in the documentation of the component. Meeting these data and conditions is compulsory.

### 3. Transport and storage

The notes regarding transport, storage and appropriate operation must be observed.

Climatic conditions must be complied to as detailed by prEN 50178.

### 4. Setting up

Setting up and cooling of the devices must be made according to the rules described in the corresponding documentation.

Drive converters are to be protected against inadmissible stress. Particularly, no components may be twisted and/or no isolation distances may be changed. Touching of electrical components and contacts is to be prevented.

Drive converters include components which can be damaged by electrostatic discharge. When handled improperly, these components can be easily damaged. Electrical components may not be damaged or destroyed by using mechanical force (this may endanger health).

### 5. Electrical connection

The valid national accident prevention regulations (e. g. VGB4) must be observed when working on drive converts which are connected to the supply voltage.

The electrical setup has to be performed according to the relevant regulations ( e. g. conductor diameter, fusing, protective conductor connection). Furthermore, the documentation contains notes concerning this subject.

Notes relevant to a proper EMC-conforming setup (e. g. screening, earthing, arrangement of filters, and cable routing) are to be found in the documentation of the drive converters. These notes must always be observed even when working with drive converters with the CE mark. The manufacturer of the plant or of the machine is responsible for the observance of the required limit values as defined by the EMC regulations.

### 6. Operation

If applicable, plants fitted with drive converts must be equipped with additional monitoring and safety devices according to the currently valid safety regulations, e. g. law concerning work equipment, accident prevention regulations, etc. Modifications of the drive converters using the operating software are admissible.

Touching of equipment parts that are subject to voltage in operating conditions and of wire connections is not allowed directly after disconnecting the supply voltage. There is the danger of still charged capacitors! Fore this, all relevant safety markings on the drive converter must be observed.

During operation, covers and doors must be kept shut.

### 7. Maintenance

The manufacturer's documentation must be observed.

**These safety notes must be kept in a safe place!**

## 2 DEVICE DESCRIPTION

### 2.1 General

The GEE series of 1-phase DC power controllers are compact devices for armature or field feeding of speed-regulated DC drives up to 40A.

The conceptualization of the device is distinguished by its compact design. An EMC-standard construction (see Chapter 4) is further supported by an enclosed, galvanized housing and the well designed terminal layout.

The main current connection spans a range of from 210 to 550V without switch-over. The electronics power supply for all devices is 230V 50/60 Hz. The electronics power supply is not required to be synchronized with the main current. The essential characteristics of the device can be determined by breaking out its type designator. Example:

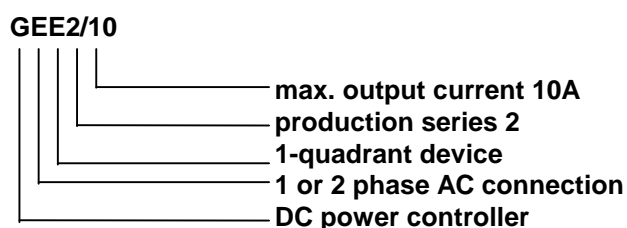

### 2.2 Device Construction

The power section consists of a semi-controlled dual pulse bridge circuit with a free-wheeling arm in typical modular construction. The supply connections (X3) are arranged on the upper side of the device. The outputs and electronics connections (X4 and X1) are located on the underside. The electronics consist of a closed-loop controller PCB and an open-loop controller PCB.

#### 2.2.1 Closed-Loop Controller PCB GEE2 A0093xx

This can be accessed by unscrewing the upper metal panel. Here you will find the electronics terminals X1 (setpoint and actual values, enable, and indicating outputs), X2 (potential terminals and secondary inputs), and everything necessary for start-up (Potentiometers, component mounts, LED-indicators). The following circuit groups are located on this board:

- A) Setpoint value integrator
- B) Speed (RPM) actual value adaptation
- C) Speed controller with current limitation
- D) Current controller
- E) Indicating outputs for RPM > 0, current limit reached, field current > 0 and device ready.

## 2.2.2 Open-Loop Controller PCB GEE2 A0126xx

This board is mounted on the left side wall. The essential elements for the electronics supply, such as the 60 Hz bridge and miniature fuses are accessible by lifting up the controller circuit board. There is nothing else on this circuit board that needs to be adjusted for start-up. The following circuit groups are located on this circuit board.

- A) Rectifier and inverter limitation
- B) Voltage determination
- C) Firing pulse generation
- D) On-off switching logic during system power loss
- E) Firing pulse output stage
- F) Electronics supply
- G) Field supply
- H) Over-voltage damping



### **Danger**

**This power controller is subject to dangerous voltages even when the main circuit breaker switch of the device is open. The open-loop controller subassembly contains many dangerous, high-voltage circuits.**

**Failure to adhere to the instructions in this operating manual can lead to death, serious bodily injury, and material damage.**

## 2.3 Ambient Conditions

The specified device's rated currents are valid up to a maximum ambient temperature of 45°C. Once this has been exceeded, a reduction of 1% per degree Celsius in the device's rated (or nominal) current must be taken into consideration. The absolute temperature limit is 55°C. Heat accumulation above the device is to be avoided. The devices have IP 00 degree of protection, i.e. they should be housed in enclosed electrical control cabinets or switch boxes. Ambient air must be kept free of electrically conductive dust particles and chemically active vapors. Vibration can ruin the devices.

## 2.4 System Power Relationships

The devices operate in a voltage range of from 230 to 500V  $\pm$  10%. For use with 60Hz power supply, the JP1 jumper must be placed onto the open-loop controller PCB. The indication „ready“ is served immediately after switching on the electronics supply and the main current. The devices require a system power supply with  $U_K = 4\%$  (for device rated current). This is achieved by interposing the recommended commutating chokes ED10-40. An auxiliary or secondary voltage of 230V  $\pm$ 10%, 50/60Hz is needed for the electronics supply.

# Temvar GEE2

## 3 PRODUCT OVERVIEW

### 3.1 Device Table

| Type    | Input Current/Fuse |     | Output Current | Power Loss | Ambient Temperature | Input Choke |
|---------|--------------------|-----|----------------|------------|---------------------|-------------|
|         |                    |     |                |            |                     |             |
| GEE2/10 | 11A                | 16A | 10A            | 60 W       | 45°C                | ED10        |
| GEE2/20 | 22A                | 25A | 20A            | 90 W       | 45°C                | ED20        |
| GEE2/40 | 45A                | 50A | 40A            | 150 W      | 45°C                | ED40        |

For 1-phase terminal, 1 x ultra-rapid semiconductor fuse  
 For 2-phase terminal, 2 x ultra-rapid semiconductor fuses

#### Common Data:

Supply voltage Main current : E 230 - 500 V /  $\pm 10\%$   
 Supply voltage Electronics : E 230 / 0.2 A /  $\pm 10\%$   
 Mains frequency : 48 - 63 Hz  
 Supply voltage Field supply : max. E 400 V  
 Output Field supply : 0.9 x UE / DC / max. 2.5A

The required DC smoothing choke conforms to the motor rated current, construction style, and rated speed, and can be approximated from the curve shown to the right. The values given are recommended values and must be agreed with the motor manufacturer in isolated instances.

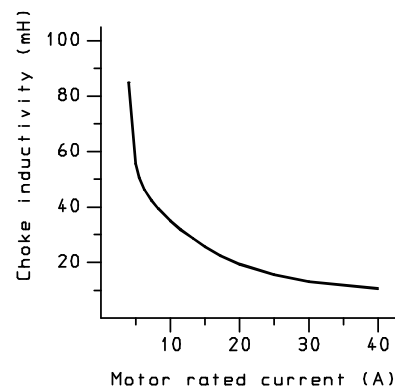

# Temvar GEE2

## 3.2 Dimensions of Chokes and Devices

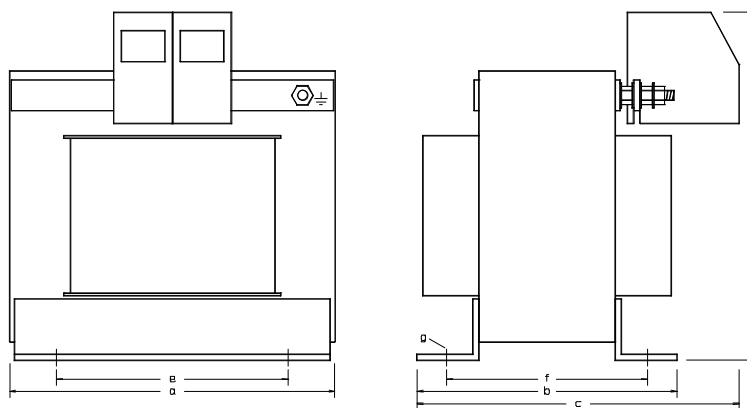
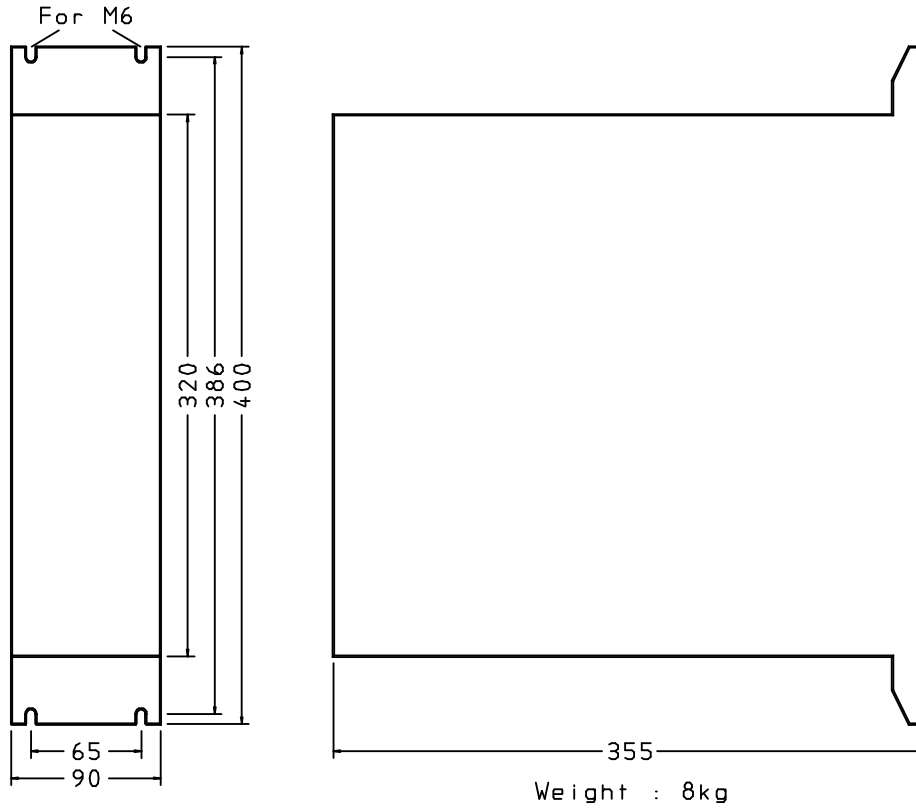

| Commutating choke |               | a   | b    | c     | d   | e  | f    | g   |
|-------------------|---------------|-----|------|-------|-----|----|------|-----|
| Type              | Rated current | mm  | mm   | mm    | mm  | mm | mm   | mm  |
| ED10              | 10A           | 84  | 76   | 106   | 90  | 64 | 63,5 | 4,8 |
| ED20              | 20A           | 97  | 88,3 | 118,3 | 106 | 84 | 72,6 | 5,8 |
| ED40              | 40A           | 120 | 91   | 121   | 115 | 90 | 73   | 5,8 |

## 4 DEVICE CONNECTION

### 4.1 Terminal Diagram

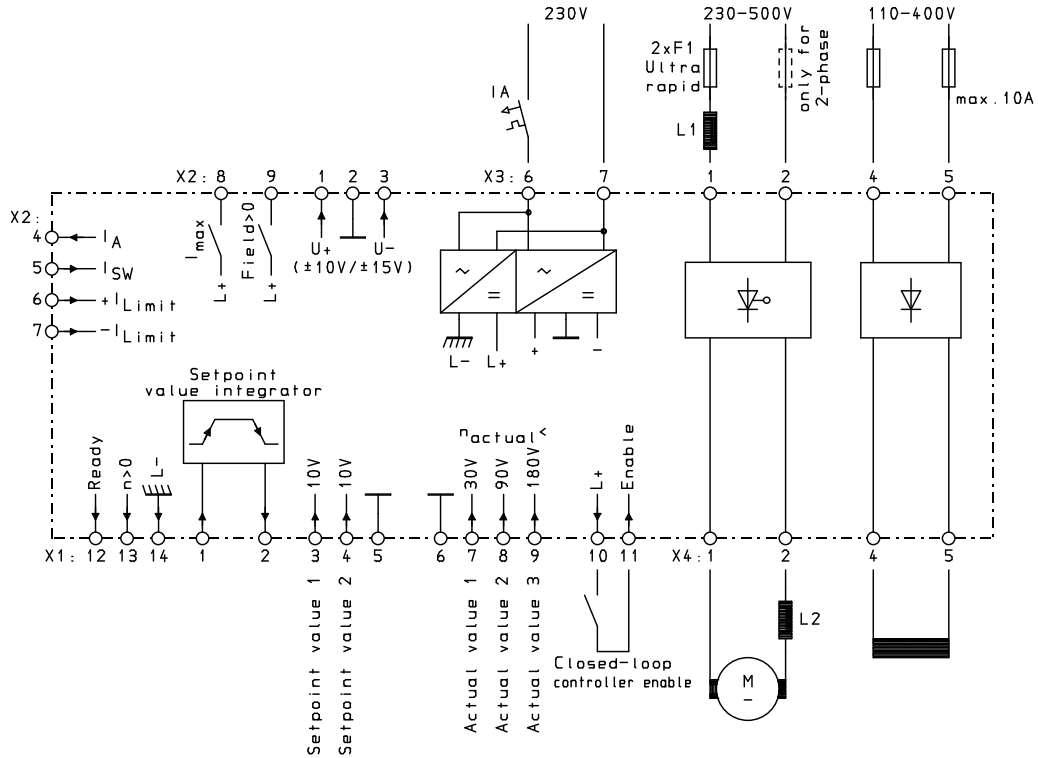

**Danger**

Improperly connecting the device can cause it to be damaged or destroyed.

### 4.2 Switch ON/OFF Sequence

#### Switching ON

- 1.) Field supply X3: 4 + 5
- 2.) Electronics supply X3: 6 + 7
- 3.) Main current X3: 1 + 2
- 4.) Closed-loop controller enable X1: 10 + 11
- 5.) Setpoint value X1: 1 or 3 or 4

Items 2 through 5 may be engaged simultaneously.

Item 1 must be engaged at least 1 second prior to engaging item 4.

The electronics supply can also be left on continuously. It does not have to be switched on and off with each operation.

## **Switching OFF**

- 1.) Setpoint value X1: 1 or 3 or 4
- 2.) During stoppage closed-loop controller enable X1: 10 + 11
- 3.) Main power X3: 1 + 2
- 4.) Field supply X3: 4 + 5
- 5.) Electronics supply

Items 1 and 2 may be switched on simultaneously.

Items 3 through 5 can be switched on together, but in any event, they must follow item 2 by at least 0.2 seconds.

The electronics supply does not have to be switched off. The motor can not turn if points 1 - 4 are switched off, but it is not potential free.

## **4.3 Terminal Allocation**

### **X1: Electronics 14-pin plug-in terminal**

- |    |   |
|----|---|
| 1  | Input setpoint value integrator max. + 10 V. Input resistance 100 k $\Omega$  |
| 2  | Output setpoint value integrator max. + 10 V. Output resistance 44 $\Omega$   |
| 3  | Setpoint value input max. $\pm$ 10 V. Input resistance 44 k $\Omega$ .<br>Filter time constant 22 ms.   |
| 4  | Setpoint value input max. $\pm$ 10 V. Input resistance 44 k $\Omega$ .<br>Filter time constant 22 ms.   |
| 5  | Closed-loop controller ground   |
| 6  | Closed-loop controller ground   |
| 7  | Actual value input max. - 30 V. Input resistance 12 k $\Omega$ .  |
| 8  | Actual value input max. - 90 V. Input resistance 30 k $\Omega$  |
| 9  | Actual value input max. - 180 V. Input resistance 48 k $\Omega$ .   |
| 10 | L+, secondary voltage + 24 V for closed-loop controller enable, indicating outputs, and auxiliary electronics. Max. load 50 mA.                 |
| 11 | Input closed-loop controller enable via optocoupler + 18 to 30 V, > 12.5 V corresponds to closed-loop controller enable. Input resistance 3K3.  |
| 12 | Output ready signal. + 24 V corresponds to "device ready to operate."<br>Max. load capacity 20 mA.  |
| 13 | Output "running" indication. + 24 V corresponds to "drive turning."<br>Max. load capacity 20 mA.  |
| 14 | L-, reference point of the independent secondary voltage 24 V for closed-loop controller enable, indicating outputs, and auxiliary electronics. |

### **X2: Electronics 9-pin plug-in terminal.**

- |   |  |
|---|--|
| 1 | Output + 15 V or + 10 V stabilized for auxiliary electronics and formation of setpoint values. Max. load 30 mA<br>The voltage can be defined using the jumper (+15/+10). |
| 2 | Closed-loop controller ground  |
| 3 | Output - 15 V or - 10 V stabilized for auxiliary electronics and formation of setpoint values. Max. load 30mA. The voltage can be defined using the jumper (+15/+10).    |



|   |   |
|---|---|
| 4 | Output current actual value. Device rated current corresponds to + 10 V.<br>Output resistance 220 Ω.  |
| 5 | Secondary input to the current controller. + 10 V corresponds to 100% of the current setpoint value.<br>Input resistance 44 kΩ. Filter time constant 2.2ms.                             |
| 6 | Input for external current limit setting. + or - 10 V corresponds to 100% (R5 Right stop) of the current limit with positive RPM setpoint value and “drive” mode. Input resistance 4K7. |
| 7 | Input for external current limit setting (R6 Left stop for 1-quadrant device).  |
| 8 | Indicator output “current limit.” + 24 V corresponds to device at the current limit.<br>Max. load capacity 20 mA.   |
| 9 | Indicating output “field current present.” + 24 V corresponds to field current greater than 0.2 A.<br>Max. load capacity 20 mA  |

### X3: Main current terminal input

|   |                     |                  |                                  |
|---|---------------------|------------------|----------------------------------|
| 1 | Main current supply | line-up terminal | 4 mm <sup>2</sup> for GEV2/10+20 |
| 2 | Main current supply | line-up terminal | 10 mm <sup>2</sup> for GEV2/40   |
| 4 | Field supply        | line-up terminal | 2.5 mm <sup>2</sup>              |
| 5 | Field supply        | line-up terminal | 2.5 mm <sup>2</sup>              |
| 6 | Electronics supply  | line-up terminal | 2.5 mm <sup>2</sup>              |
| 7 | Electronics supply  | line-up terminal | 2.5 mm <sup>2</sup>              |

### X4: Main current terminal output

|   |                   |                  |                                  |
|---|-------------------|------------------|----------------------------------|
| 1 | Armature terminal | line-up terminal | 4 mm <sup>2</sup> for GEV2/10+20 |
| 2 | Armature terminal | line-up terminal | 10 mm <sup>2</sup> for GEV2/40   |
| 4 | Field terminal    | line-up terminal | 2.5 mm <sup>2</sup>              |
| 5 | Field terminal    | line-up terminal | 2.5 mm <sup>2</sup>              |

## 4.4 Assembly

### 4.4.1 Danger

Improper lifting can lead to bodily injury or material damage.

Only lift the device with the appropriate gear and using appropriately qualified personnel.

Device fitting must be conducted in accordance with the safety regulations (e.g. DIN, VDE) and all other relevant governmental or local regulations. Sufficient grounding, wire sizing, and appropriate short-circuit protection must be present in order to ensure operational safety.

## 4.4.2 Mechanical Construction

For reasons of electromagnetic compatibility (EMC), the devices have a galvanized steel housing. For the same reason, a galvanized mounting plate is recommended, along with connecting the ground lead to a copper bus connected to the mounting plate via a broad, conductive surface area (see construction suggestions).

In order to ensure an unimpeded flow of cooling air, an interval of at least 100mm above and below the device must be kept clear of obstruction.

Failure to maintain this interval will result in the device overheating!

The main current fuses must be ultrafast semiconductor fuses.

## 4.4.3 Wiring Notes

All leads connected to terminal strips X1 and X2 must be shielded. The shielding should be firmly attached using terminals, clips, or binders, across a broad contact surface on the bus bar provided for that purpose. Analog signal leads should only be grounded at one point. Leads with binary control signals can be grounded at several points. The wiring paths should be kept short and the electronics wiring should be strictly isolated from the main current wiring. (see the construction suggestions).

The closed-loop controller ground should be connected to the protective ground system by a short 2.5<sup>2</sup> litz wire.

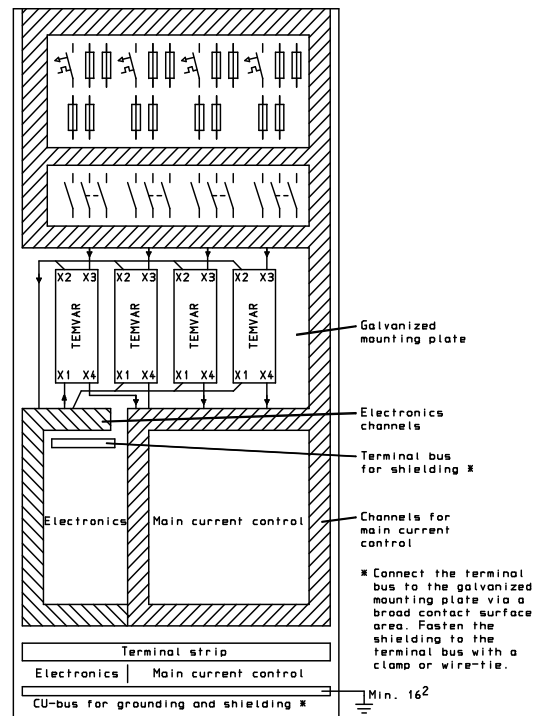

## 5 OVERVIEW DIAGRAMS

### 5.1 Circuit Diagram

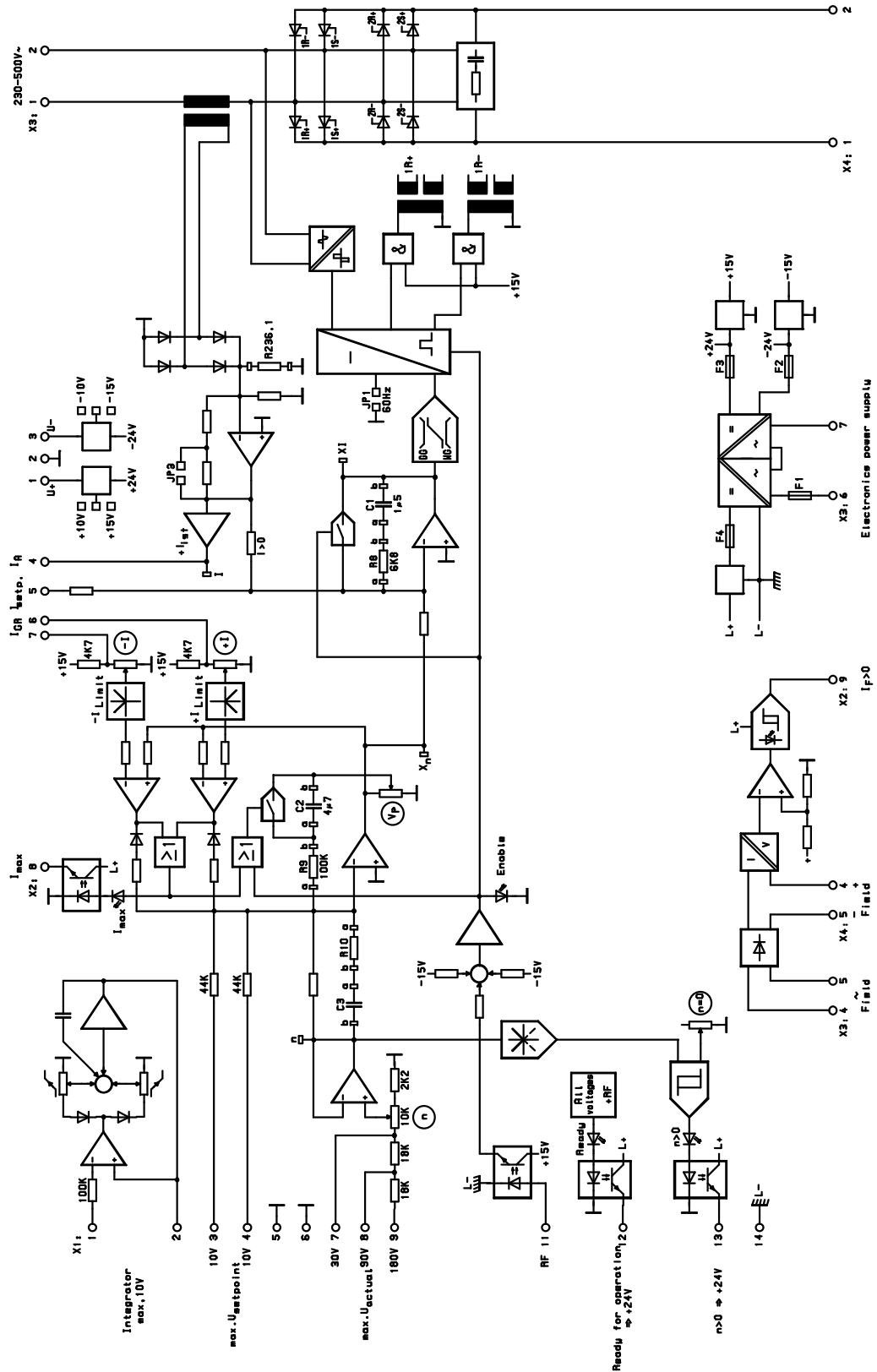

## 5.2 Device Mounting

- X1: Electronics terminal strip  
Primary function
- X2: Electronics terminal strip  
Secondary function
- X3: Input terminals  
Main current
- X4: Output terminals  
Main current

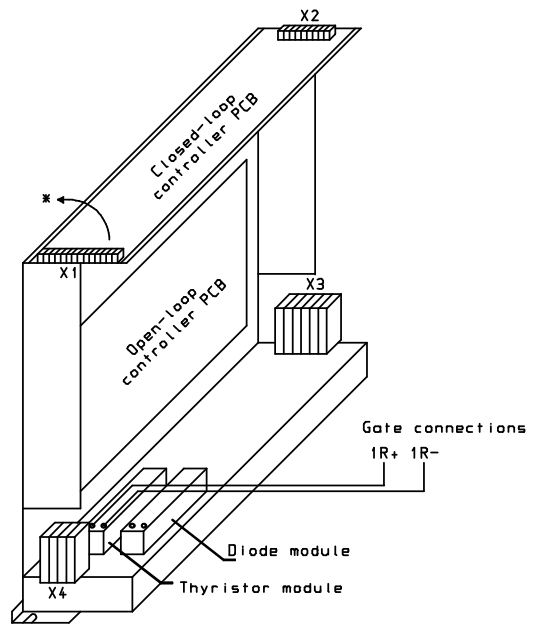

### Thyristor module / Diode module:

|           |   |                   |                 |
|-----------|---|-------------------|-----------------|
| GEE2 - 10 | : | 1 x 19 - 16 io 1B | 1 x 26 - 12 N1B |
| GEE2 - 20 | : | 1 x 19 - 16 io 1B | 1 x 26 - 12 N1B |
| GEE2 - 40 | : | 1 x 44 - 16 io 1B | 1 x 44 - 12 N1B |

The miniature fuses for the electronic supply are located on the open-loop controller PCB. This PCB can be accessed by folding away the closed-loop controller PCB in the direction indicated by the arrow.\*



### **Danger**

**This power controller is subject to dangerous voltages even when the main system circuit breaker is open. The open-loop controller PCB contains many dangerous, high-voltage electrical circuits.**

**Failure to adhere to the instructions in this operating manual can lead to death, serious bodily injury, and material damage.**

## 5.3 Component Mounting Diagram for the Electronics Circuit Boards

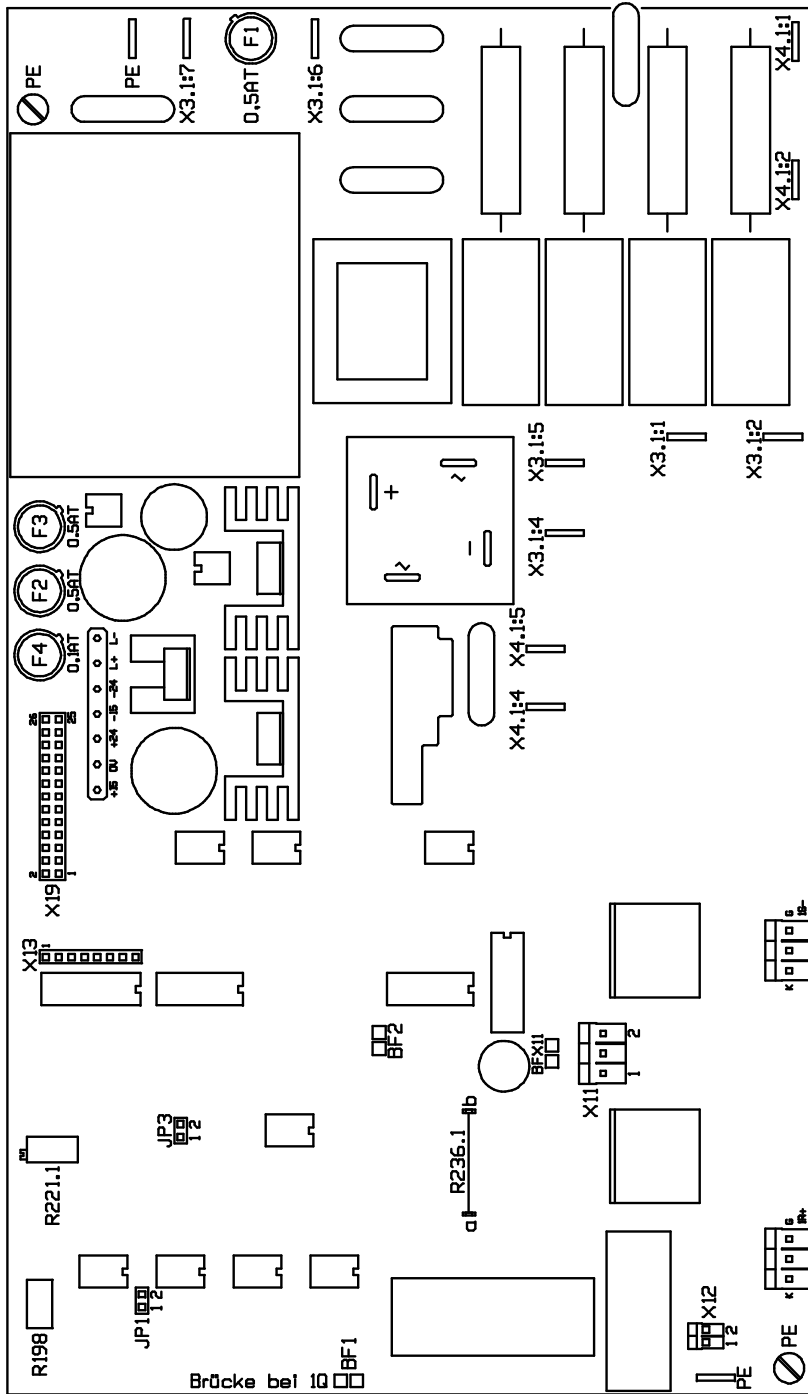



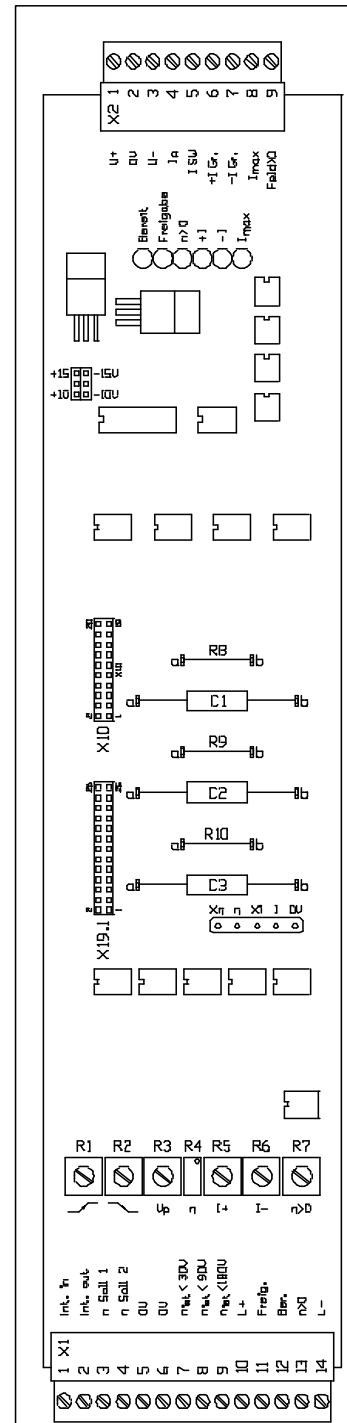











Open-loop controller circuit board  
GEE2  
A0126xx



Closed-loop controller circuit board  
GEE2  
A0093xx

## 5.4 Potentiometer Settings

- +B**  **R1**  Setpoint value integrator. Acceleration time with positive setpoint value. Left stop, approx. 1.5 seconds, right stop, approx. 15 seconds. Run-up time from 0 to 10V.
- B**  **R2**  Setpoint value integrator. Deceleration time with positive setpoint value. Same effect as +B.
- V<sub>P</sub>**  **R3**  Proportional amplification for the speed controller. Left stop = 2 times. Right stop = 20 times. This range is determined by R9 as delivered.
- n**  **R4**  25-gang spindle trimmer for speed trim. Setting range approx. 1 : 4. Turning toward the right means a higher speed.
- +I**  **R5**  Current limit with positive speed setpoint value. Left stop results in current limit 0, right stop results in current limit 100% of the device rated current.
- I**  **R6**  Current limit for 4-quadrant devices (left stop for 1-quadrant devices).
- n > 0**  **R7**  Running indicator threshold adjustable from 0 to 15% of the maximum speed. Right stop means 15%.

## 5.5 LED Indicators

### READY



LED illuminates when all internal electronic voltages are in order and the main current is switched on.

### CLOSED-LOOP CONTROLLER ENABLE



LED illuminates when the device is ready and the closed-loop controller is enabled by a +24V signal at terminal 11.

### $n > 0$



LED illuminates when the drive is turning faster than the potentiometer threshold setting  $n > 0$ .

### Current Direction “+”



The LED indicates 1-quadrant operation.

### Current Direction “-”



This indication only applies to 4-quadrant in operation.

### Current Limit



LED illuminates when the motor is operated at least 15 seconds at the set current limit, i.e. the speed controller is being operated at the stops which are set using the potentiometer I+ or by an external voltage.

## 6 DESCRIPTION OF THE INPUT AND OUTPUT FUNCTIONS

### 6.1 Analog Inputs

The analog inputs may only be connected using shielded leads. The shield should only be connected to the grounding system at one point, across a broad contact surface in close proximity to the device. For reasons of electromagnetic compatibility, these leads may never be operated open-circuit, they must be connected with respect to the electrical ground when the device is switched off.

#### Setpoint Value Integrator

The input voltage range is 0 to + 10 V.

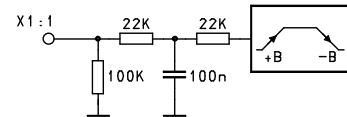

#### Setpoint Value Inputs

The two inputs are equal and cumulative. The maximum input voltage range is 0 to + 10 V. Input resistance and filter time constant are 44kΩ and 22ms, respectively.

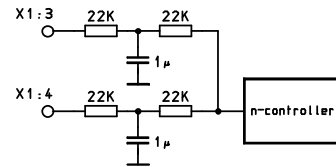

#### Actual Value Inputs

The “speed trim” potentiometer is a 25-gang spindle trimmer with a setting range starting at 1 : 4. Right stop means the highest rate of speed. For dynamic reasons, the filter time constant is set very low (approx. 2.2ms). The tachometer voltage must therefore be very clean.

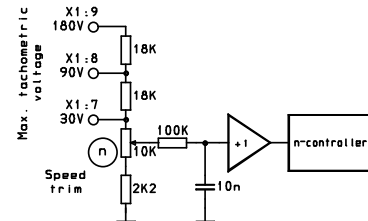

#### Inputs “external current limit”

The maximum motor current is set using potentiometer +I (Right stop 100% device rated current). An external voltage of from 0 to +10V at X2: 6 means 0 to 100% device current. The input is provided with an active rectifier and can therefore operate at + 10V or - 10V (Input resistance 4K7).

The set current limit can be reduced by switching-in a resistance to ground.

Only 4-quadrant devices have a negative current limit. For this device, potentiometer -I is on left stop.

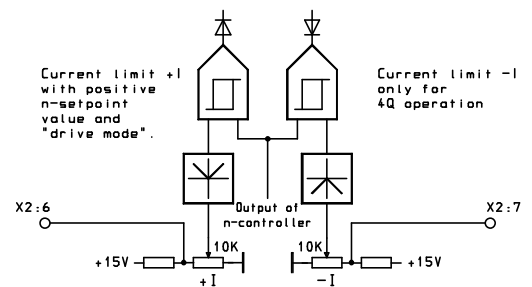



## Secondary Input Current Controller

A voltage of +10V at terminal X2: 5 means device rated current.

### Attention!

This secondary setpoint value adds itself to the main setpoint value from the speed controller. The two current limits must be set low enough that the sum of the two setpoint values is + 10V max. This input has a very short filter time constant (2.2ms). Therefore, a very clean voltage must be maintained at terminal X2: 5.

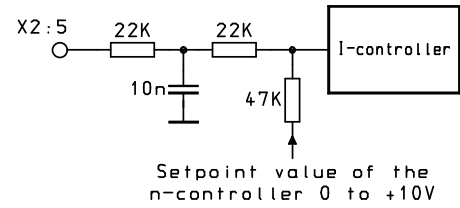

## 6.2 Analog Outputs

### Setpoint Value Integrator

The output is protected from back interference voltages by a low-pass filter and 2 pull-up/pull-down diodes. This results in a negligible degree of load control which is completely inconsequential, however, under a constant load (e.g. when a connection is made to the setpoint inputs X1: 3 or 4).

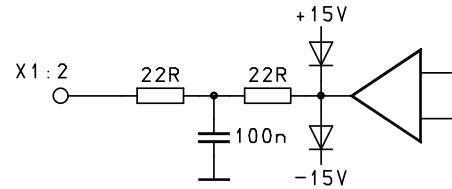

### Current Actual Value

Where the current is the device rated current, a voltage of +10V. Output resistance 220Ω.

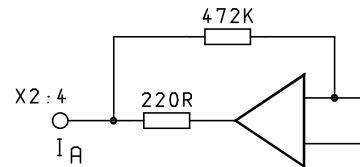

## 6.3 Control Inputs and Indicator Outputs

Inputs and outputs are separated from the electronics potential by optocouplers. These have their own 24V power supply designated by +L and -L.

The reference potential -L, terminal X1: 14, is to be connected to the reference potential of the system control unit. It is recommended that the input and output wiring be shielded.

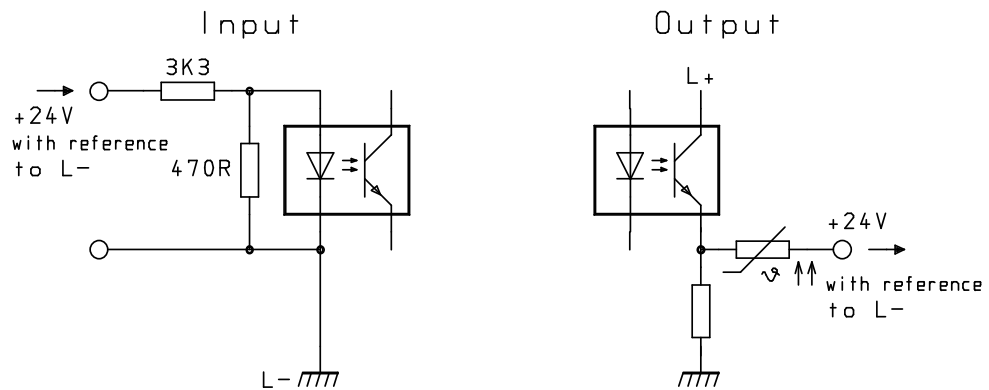

**Danger**

**When controlling the binary control and selection inputs via an external voltage source which is independent of ground (do not connect X1: 14 with X1:5 or 6), the difference in potential between device ground and the ground of the external voltage is not allowed to not exceed 50V (danger to optical coupler).**

### Input Controller Enable

Controller enable means: Apply voltage +L to terminal X1: 11, or apply an external voltage of +15 to +30V whose reference point is connected to -L (terminal X1:14). When a voltage is less than +10V, the controller is safely inhibited. When the controller is inhibited, the firing pulses are also suppressed. The drive does not drift when it is shut off, but it also does not produce any momentum. When disengaging the drive, the controller must be inhibited for a period of at least 200ms before switching off the main current.

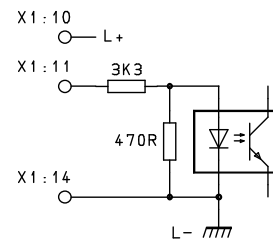

### Indicator Output “Ready for Operation”

At terminal X1: 12, the voltage +L is applied when the electronics power supply and the main current is present. In the 40 A device, which has a cooling fan built-in beneath terminal X4, a temperature switch is included in this ready indication.

When the heat sink temperature exceeds 85° C, the ready indication is extinguished. The output is short-circuit proof.

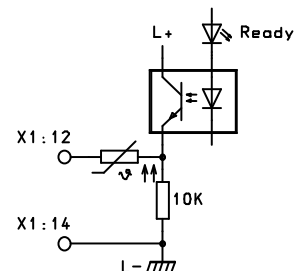

# Temvar GEE2

## Indicator Output $n > 0$

+L is applied at terminal X1: 13, when the drive turns faster than the  $n > 0$  threshold which was set at the potentiometer. The output is short-circuit proof.

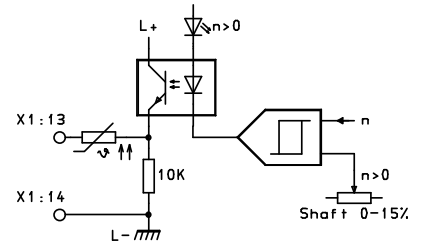

## Indicator Output "I max."

+L is applied at terminal X2: 8, when the drive is operated longer than 15 seconds at the set current limit. . The output is short-circuit proof.

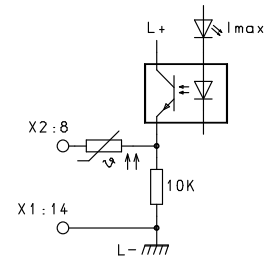

## Indicator Output "field current present"

This output only pertains when the field rectifier built into the device is used. (Terminals X3: 4 + 5/ X4: 4 + 5). +L is applied to terminal X2: 9 when the field current is greater than 0.2A. This is not indicated by an LED. The output is short-circuit proof.

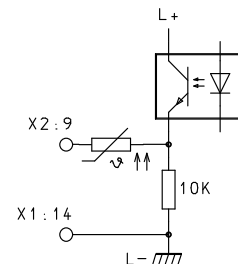

## 7 DESCRIPTION OF FUNCTIONS

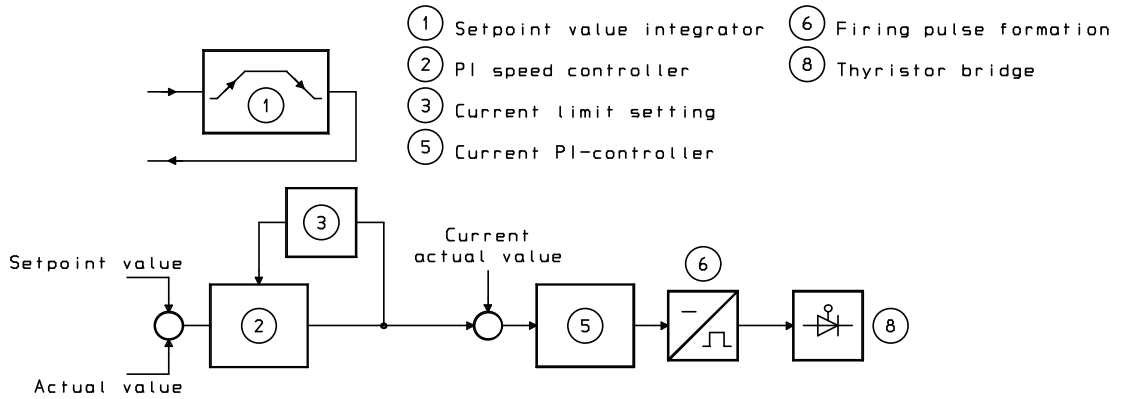

- ① Setpoint value integrator
- ② PI speed controller
- ③ Current limit setting
- ④ Current PI-controller
- ⑤ Firing pulse formation
- ⑥ Thyristor bridge

### 7.1 Setpoint Value Integrator

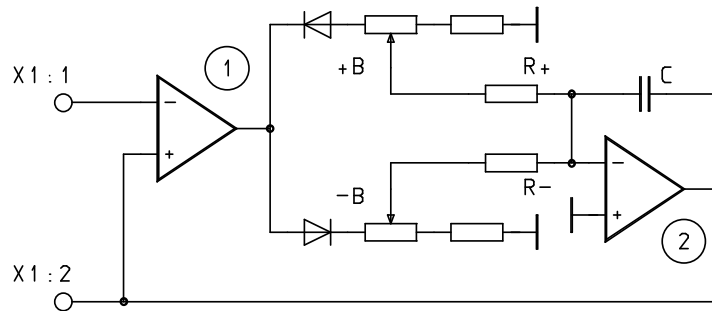

When a positive jump in setpoint value occurs at terminal X1: 1, the comparator (1) trips over to negative. Capacitor C becomes charged via resistance R+. The rate of charging is dependent upon the potentiometer setting +B. When the output voltage at the integrator (2) has reached the level of the setpoint value at X1: 1, the comparator (1) again trips over to 0 and capacitor C is no longer charged.

When the setpoint value is negative, the same applies using potentiometer -B and charging resistance R-. Whenever a positive setpoint value is reduced, the comparator (1) trips over to positive and capacitor C is discharged via potentiometer -B and resistance R-.

## 7.2 Speed Closed-Loop Controller

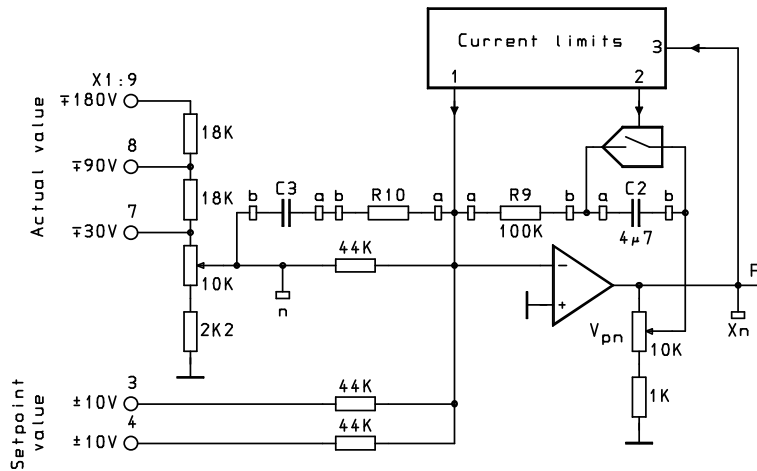

T

he speed controller is an ordinary closed-loop PI-controller. The proportional amplification is determined by R9 and potentiometer  $V_P$  and the integral-action time by C2. The right stop of potentiometer  $V_P$  means the greatest amplification. The controller output can be measured at measurement test point "X." The PI-controller can be expanded to a PID-controller via C3 and R10. The actual speed, normalized to the setpoint value level, can be measured at measurement test point "n."

## 7.3 Current Limits

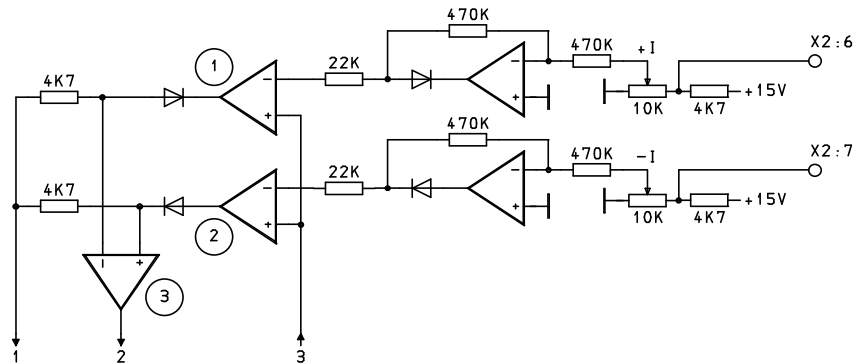

Com

parators (1) and (2) are biased between 0 and 10V using potentiometers +I and -I. Comparator (1) is tripped over to positive, comparator (2) to negative. If the speed controller output (item 3) exceeds the set bias voltage, then the affected comparator trips over. The controller output is again taken back to the mixing point of the speed controller (item 1) via the corresponding diode and the relatively low resistance 4K7.

At the same time, the comparator (3) will trip over to positive and short the capacitor C2 via the speed controller using an FET-switch. This switch is laid out for 4-quadrant operation. Since the GEE device series only allows for 1-quadrant operation, the potentiometer -I is turned to the left stop. The bias voltage of max. 10V can also be externally connected to terminal X2: 6. (Input resistance 4K7)

## 7.4 Closed-Loop Current Controller

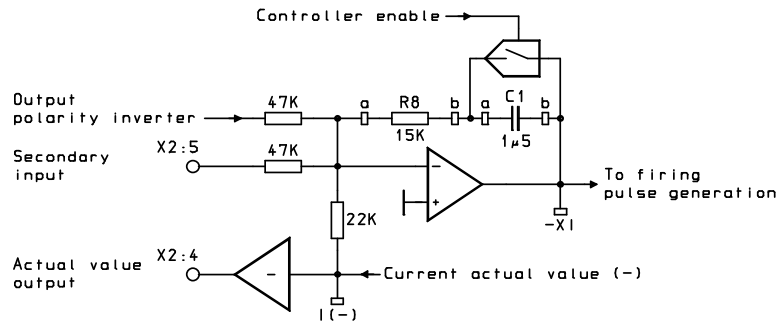

The current controller is an ordinary closed-loop PI-controller. The proportional amplification is determined using R8, the integral-action time using C1. When using the secondary input X2: 5, care must be taken that both setpoint value inputs are cumulative. The sum may not exceed +10V. The current controller output can be measured at measurement test point - X1. The current actual value (+ 10V with device rated current) is applied to terminal X2: 4. The voltage is smoothed with a time constant of 200ms.

Formation of the current actual value takes place on the open-loop controller circuit board. By increasing the load resistance R236/236.1, or by moving the jumper J3, every value can be limited to a value below the device rated current. Decreasing the load resistance is not permitted.



### Danger

**When using the secondary input X2: 5, the device and the motor can be overloaded or the drive can exceed RPM during run-up. The current limit has no effect on input X2: 5.**

## 7.5 Firing Pulse Formation

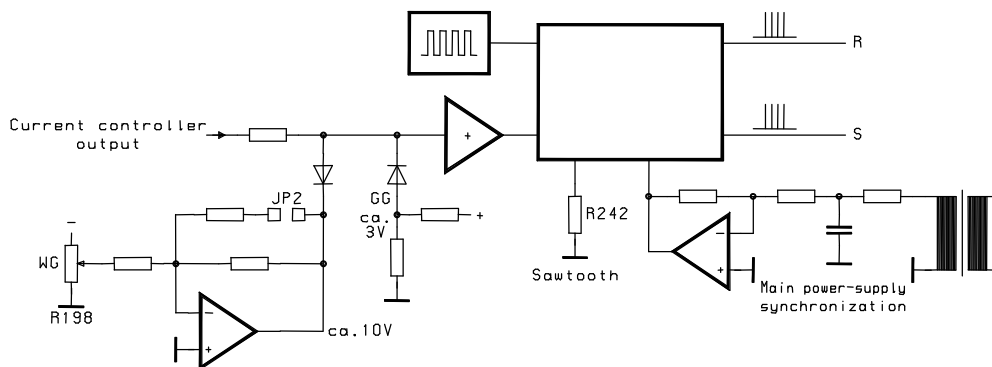

The integrated firing pulse element is controlled by the output voltage of the current controller. The firing pulses have a length of approx. 1 ms and are divided into 100µs-cycles.

The rectifier limit (GG) is fixed, the inverter limit (WG) is set at the factory and may not be altered. For use with 60 Hz systems, the jumper IP1 must be placed on the open-loop controller circuit board.

## 7.6 Thyristor/Diode Output Stage

The selected current direction +I activates the corresponding pulse transformer and enables the AND-gate for the firing pulse.

The item in question is a semi-controlled dual pulse bridge circuit in which both rectifying diodes take over the free-wheel arm simultaneously.

The thyristors require a holding current of approximately 100 mA. If this current is not reached during the firing phase, the thyristor ceases conducting after the firing pulse is removed.

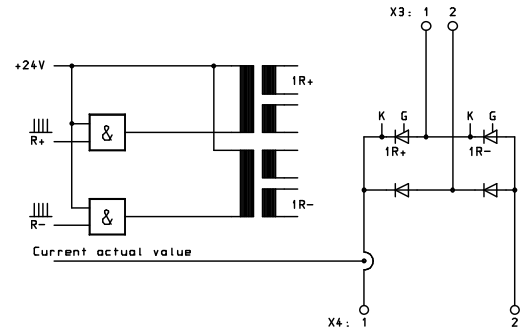

## 7.7 Electronics Supply

A system power supply of 230V/50-60 Hz is needed for the electronics power supply. A tolerance of  $\pm 10\%$  is allowed. Slow-blowing miniature fuses 5 x 25mm are used. The  $\pm 15$  V and L+/L- are stabilized with linear controllers. The  $\pm 24$  V is only filtered

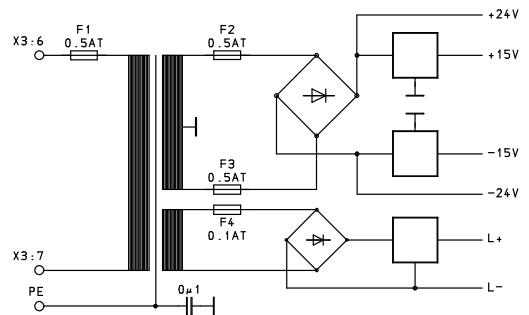

## 7.8 Field Supply

The power controller can be connected to a maximum voltage of 400V and bear a max. current load of 2.5A. When a current is greater than 0.2A, the potential +L is applied to indicator output X2: 9. The output is short-circuit proof.

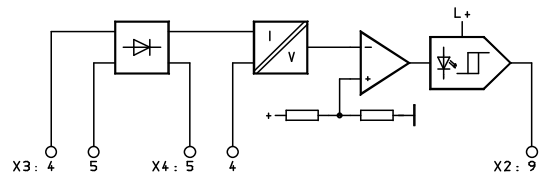

## 8 START-UP

### 8.1 Danger

When this device is in operation, certain components are subject to dangerous voltages, which can lead to serious bodily injury or death. The following precautionary measures should be taken in order to reduce the danger of death or injury.

1. Only qualified personnel who are familiar with this device and the accompanying information should be allowed to assemble, operate, trouble-shoot, clear, or repair it.
2. Device fitting must be carried out in accordance with safety regulations (e.g. DIN, VDE) and all other relevant state or local regulations. In order to ensure operational safety, the device must be equipped with regulation grounding, wire sizing, and appropriate short circuit protection.
3. Keep all panels and doors closed during normal operations.
4. Before carrying out visual inspections and servicing, ensure that the AC power supply is switched off and locked. Both the power controller and the motor are subject to dangerous voltages prior to switching off the AC power supply. Dangerous voltages are present even when the circuit breaker to the power controller is open.
5. Under no circumstances may the terminals be touched when measurements are being taken while the main power supply is switched on. Remove all jewelry from wrists and hands. Ensure that meters and other test devices are in good working order.
6. When working on an energized device, stand on an isolated surface, i.e. ensure that you are not grounded.
7. Follow the instructions in this operating manual exactly and observe all danger, warning, and cautionary notices.
8. This list does not represent a complete listing of all measures required for safe operation of this device. If you need further information or should special problems arise, please consult the manufacturer.



## 8.2 Recommended Actions



### Danger

**No supply voltage may be applied to the device until step 4 of the start-up procedures. When controller enable is input, the drive runs up!**

1. Check all main power protective conductors, and electronics connectors for correct connection. Check fuses against device table 3.1..
2. Using an ohmmeter, check the armature connection (1 - 10  $\Omega$ ), the field connection (100 - 500  $\Omega$ ), and the tachometric connection (approx. 80  $\Omega$ ).
3. Set potentiometer +I to approx. 30%. Set all other potentiometers to the left stop. Disconnect the controller enable terminal X1: 11. Disconnect setpoint value (terminal X1: 1 or 3 or 4) and connect manual potentiometer to terminal X2: 1 + 2. Connect collector ring to X1: 3. Preselection voltage terminal X2:1 to 10V.  
  
Determine the maximum expected tachometer voltage and check to see if the correct actual value input is used. Connect the voltmeter to this terminal.
4. Switch on the device and measure the main power at terminal X3: 1 + 2, the field infeed at X3: 4 + 5, the electronics power supply at X3: 6 + 7, and the field voltage at X4: 4 + 5. Using the manual potentiometer, set the setpoint value to approx. + 1V.
5. Briefly touch the free "controller enable" wire to terminal X1: 11. The voltmeter must show a negative deflection upon sensing the actual value input. If this is the case, the wire can be firmly connected and the machine's direction of rotation can be checked. If the direction of rotation is incorrect, swap out or reverse the field and tachometer connections.
6. Set current limits to the motor's rated current. Set the setpoint value potentiometer to +10V. Trim the speed with spindle trimmer "n." While trimming, the armature voltage may not exceed the value on the serial no. plate. Reduce the field current if necessary.



### Danger

**Too great an overshoot can cause the allowable armature voltage to be exceeded. Jumps in the setpoint value in field suppressed areas can cause an overshoot of the armature current.**

7. Disconnect manual potentiometers, apply system setpoint values, and test the emergency shut-off function with system setpoint values.

## 9 OPTIMIZING

For most applications, the standard arrangement of the current and speed controllers is completely sufficient. It is advisable, however, to check the motor's transient response for jumps in setpoint value and to optimize it using the  $V_p$  potentiometer. Should a critical drive be in need of more precise optimization, it is recommended that the following steps be taken once the drive is in operation. Speed controller optimization should be carried out with the machine engaged.

### A) Current controller optimization

1. Connect the current setpoint value potentiometer and controller enable switch according to the following diagram.

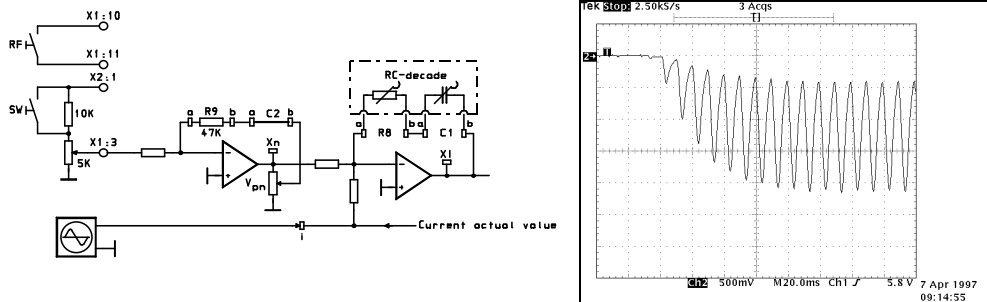

2. Wire the speed controller according to the diagram. Turn potentiometer  $V_p$  to left stop.
3. Connect RC-decode according to diagram. Beginning with the standard arrangement. Connect oscilloscope to test point "I."
4. Disconnect field supply. Bridge the field current monitoring.
5. Engage drive, release the controller. Set the potentiometer at terminal 3 so that a non-pulsing current is just present. Input the setpoint value jump with the SW switch. Optimize the current controller, first with R8, then with C1, so that the oscillogram appears as it does in the example.

### B) Speed Controller Optimization

1. Connect the potentiometer for speed setpoint value, the controller enable switch, and the RC decode according to the following diagram.

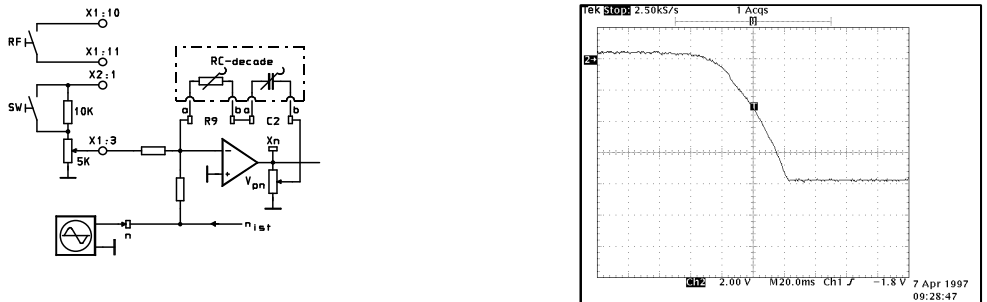

2. Connect the field power supply. Set the RC decade to standard arrangement, and the potentiometer  $V_{P-}$  to mid-range.
3. Engage the drive, then enable the controller.  
Set approx. 30% of the maximum speed and input the setpoint value jump with switch SW. Optimize the speed controller, first with R9, then with C2, so that the oscillogram appears as it does in the example. The transient response of the speed controller, particularly when accelerating or positioning large masses, can often be improved using a D-element R10/C3. Suggested values for dimensioning are approx.  $22k\Omega$  and  $1\mu F$ .

## 10 MALFUNCTIONS



### Danger

**When electrical devices are in operation, certain device components will naturally be subject to dangerous voltages.**

**Dangerous voltages can be present at the user end of indicator relays.**

**Improper use of this equipment can therefore lead to death, serious bodily injury, or considerable material damage.**

**Observe all notices listed in this chapter and located on the product itself when performing maintenance on this device.**

**Maintenance of the device may only be carried out by appropriately qualified personnel who have previously read and understood all safety, assembly, operation, and servicing instructions contained in this description.**

**Before carrying out visual inspections or servicing work, ensure that the AC power supply is switched off and locked and that the device is grounded. The power controller and the motor are both subject to dangerous voltages prior to switching off the AC power supply. Dangerous voltages are present even when the power controller's circuit breaker is open.**

**Only replacement parts approved by the manufacturer may be used.**

- A) Main current fuse is defective.

Check the thyristors: Measure terminals X3: 1 + 2 with an ohmmeter.

Resistance must be greater than  $40k\Omega$ .

Measure X3: 1, then X4.1, then X3: 2, then X4.2, Resistance must be greater than  $100k\Omega$ .

Checking the Diodes:

Measurement of X3: 2 then X4: 1 with positive (+) lead of the Ohmmeter at X3: 2, throughput must be determined. X3: 2 then X4: 2 must inhibit.

By switching the polarity of the ohmmeter leads, the second diode can now be measured. The function is reversed.

# Temvar GEE2

B) Drive is not turning.

Presupposing that:

Wiring and fuses are in order.

Engage the drive (positive setpoint value).

LEDs:

|   |                                |     |     |     |     |     |
|---|--------------------------------|-----|-----|-----|-----|-----|
| ⊗ | Ready                          | On  | Off | On  | On  | On  |
| ⊗ | Closed-loop controller release | On  | Off | Off | On  | On  |
| ⊗ | $n > 0$                        | Off | Off | Off | Off | Off |
| ⊗ | Current direction +            | On  | Off | On  | On  | On  |
| ⊗ | Current direction -            | Off | Off | Off | Off | Off |
| ⊗ | Current limit                  | Off | Off | Off | On  | On  |
|   | Case                           | 1   | 2   | 3   | 4   | 5   |

Case 1: Setpoint value at terminal X1: 3 or 4 (against reference point X1: 5 or 6) probably not present.

Case 2: Measure electronics power supply  $\pm 15V$  or  $\pm 10V$  at terminal X2: 1 + 3. If not present - check the supply at X3: 6 + 7 and miniature fuses F1, F2, F3 on the open-loop controller circuit board. If present, measure the main connection voltage at X3: 1 + 2. For the GEE2 / 40, check the thermocontact.

Case 3: No command given for controller enable. Measure + 24V at terminal X1: 11 against reference point X1: 14. If not present, check the miniature fuse F4 on the open-loop controller PCB.

Case 4: Potentiometer current limit I+ is turned to zero.

Case 5: Potentiometer current limit I+ not turned up far enough. Measure the output voltage at X4: 1 + 2. If present - armature wire is broken.